

INSTRUCTION MANUAL

Orion SkyQuest™ XT4.5 Dobsonian Reflector

#10014



**ORION**
TELESCOPES & BINOCULARS
Providing Exceptional Consumer Optical Products Since 1975

Customer Support (800) 676-1343
E-mail: support@telescope.com
Corporate Offices (831) 763-7000
89 Hangar Way, Watsonville, CA 95076

© Copyright 2001-20012 Orion Telescopes & Binoculars

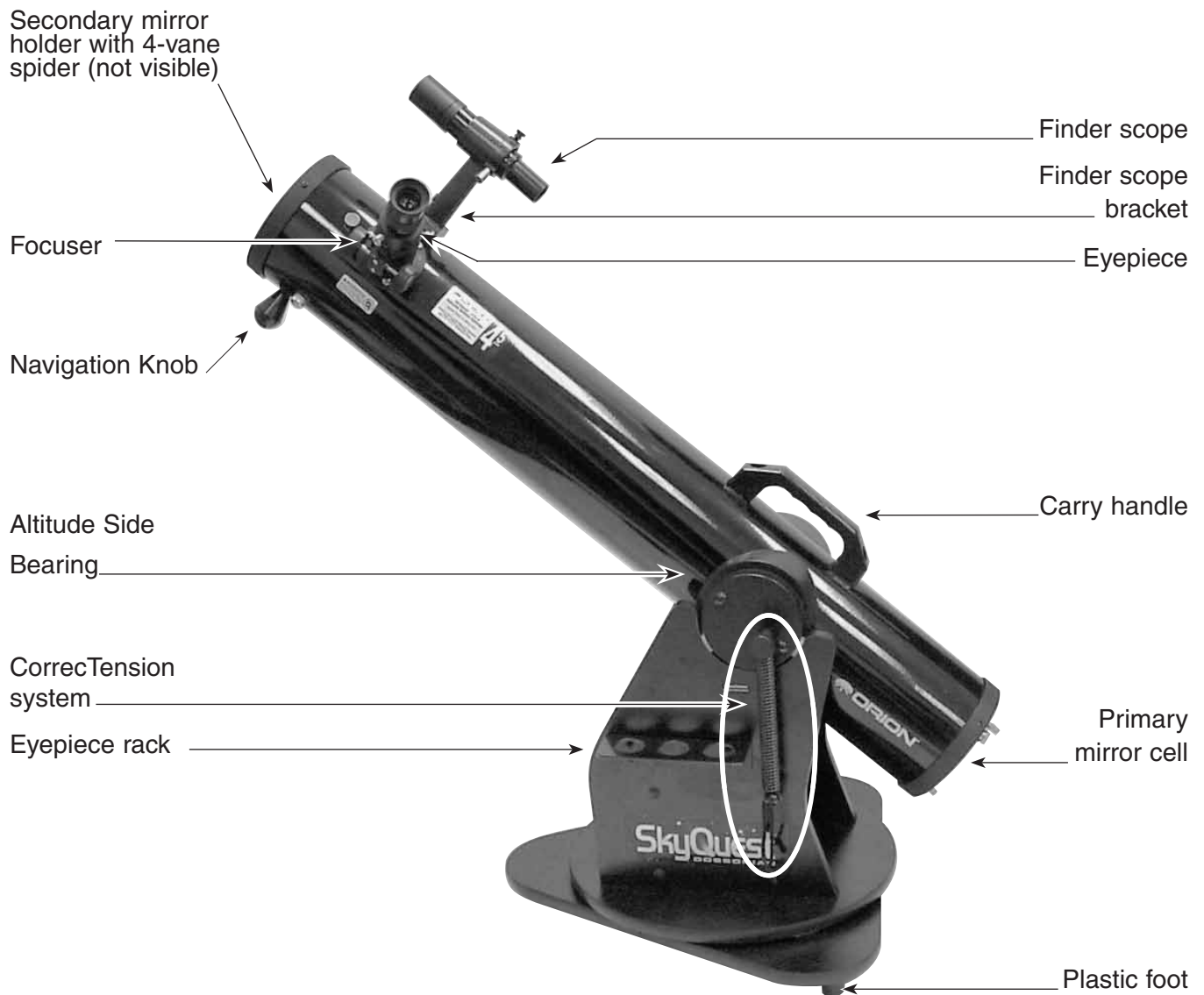

Figure 1. The SkyQuest XT4.5 parts diagram.

Welcome to an exciting new world of adventure! Your SkyQuest XT4.5 Dobsonian is a high-quality optical instrument designed to bring you dazzling views of the outer reaches of our universe. Easy enough for kids to use, and portable enough for anyone to carry, the SkyQuest XT4.5 will provide fun and entertainment for the entire family. Whether you are brand-new to amateur astronomy or a seasoned stargazer, get ready for many evenings of enjoyment and fascination. Before venturing into the night with your new telescope, we recommend that you read through this instruction manual. Not only does it provide accurate directions for assembly and use, but it also serves as a guide for your first explorations in the sky. It is not necessary to immediately read the appendix sections at the end of the manual; they contain detailed information regarding aligning and cleaning the telescope's optics, which should not be needed initially.

Table of Contents

1. Unpacking.....	3
2. Assembly	4
3. Using Your Telescope.....	6
4. Observing Tips.....	9
5. Astronomy Basics	10
6. Care and Maintenance	13
7. Specifications.....	13
Appendix A: Collimation (Aligning the Mirrors)	14
Appendix B: Cleaning the Optics	15

1. Unpacking

The telescope will arrive in two boxes, one containing the optical tube assembly and accessories, the other containing the unassembled Dobsonian base. Be careful unpacking the boxes. We recommend keeping the original shipping containers. In the event that the telescope needs to be shipped to another location, or returned to Orion for warranty repair, having the proper shipping containers will help ensure that your telescope will survive the journey intact.

Make sure all the parts in the Parts List below are present. Be sure to check boxes carefully, as some parts are small. If anything appears to be missing or broken, immediately call Orion Customer Support (800-676-1343) for assistance.

WARNING: *Never look directly at the Sun through your telescope or its finder scope—even for an instant—without a professionally made solar filter that completely covers the front of the instrument, or permanent eye damage could result. Young children should use this telescope only with adult supervision.*

Parts List

Box #1: Optical Tube Assembly and Accessories

Qty.	Description
1	Optical tube assembly
1	Optical tube Dust cover
1	25mm Sirius Plössl eyepiece, 1.25" barrel diameter
1	10mm Sirius Plössl eyepiece, 1.25" barrel diameter
1	Eyepiece rack w/mounting wood screws
1	6x26 Correct-Image finder scope w/O-Ring
1	Finder scope bracket
2	Spring coils
2	Pull loops
1	Collimation cap
4	Nylon spacers (black)
2	1/4" washers (black)
2	Phillips head screws (black, length 1-1/2")

Box #2: Dobsonian Base

Qty.	Description
1	Left panel
1	Right panel
1	Front brace
1	Top baseplate
1	Ground baseplate
10	Base assembly screws
4	Trim caps (black)
3	Plastic feet
3	Feet attachment wood screws (length 3/4")
1	Self-adhesive rubber bumper
1	Large hex-head bolt (length 2")
2	3/8" washers
1	3/8" lock nut
1	Nylon spacer (white)
1	T-nut

2. Assembly

Now that you have unpacked the boxes and familiarized yourself with all the parts in front of you, it's time to begin assembly. The optics of the telescope are already installed in the tube, so most of the required assembly concerns the Dobsonian base.

Assembly of the Dobsonian base

Refer to Figure 2 during base assembly. The base need only be assembled once. The assembly process takes about 30 minutes and requires a Phillips screwdriver, and an adjustable crescent wrench. When tightening screws, tighten them until firm, but be careful not to strip the holes by over-tightening. Children under the age of 12 should work with an adult.

1. Screw the plastic feet into the underside of the ground

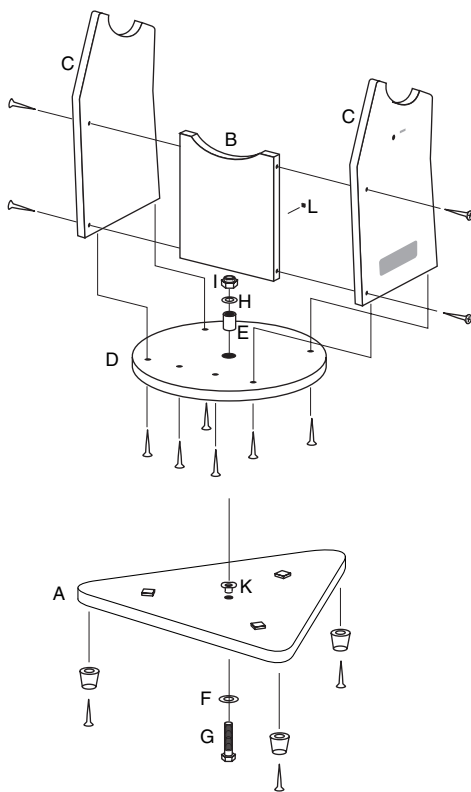

Figure 2. Exploded view of the Dobsonian base.

baseplate (A) using the self-tapping wood screws provided, with a Phillips screwdriver. Insert the screws through the feet and thread them into the predrilled starter holes.

2. Loosely attach the front brace (B) to the two side panels (C) with four of the base assembly screws in the predrilled holes. The side panels should be oriented so the SkyQuest labels are facing outward. Do not completely tighten the screws yet.

3. Attach the two sides (C) with the front brace attached to the top baseplate (D) with the remaining six base assembly screws in the predrilled holes. Tighten all six screws.

4. Tighten the four side screws installed earlier. Press a trim cap onto the heads of each of these screws.

5. Insert the white nylon bushing (E) into the hole in the center of the top baseplate (D). Tap the nylon bushing in so it goes all the way into the top baseplate. The nylon bushing should be flush with the top surface of the top baseplate.

6. Insert the T-nut (K) into the center hole of the ground baseplate (A) so the nut's flanged top is on the same side of the baseplate as the PTFE/UHMW pads. Thread the large hex-head bolt (G) with a 3/8" washer (F) attached up through the ground baseplate and through the T-nut until it is tight.

7. Now position the top baseplate (D) (with side panels attached) over the ground baseplate and lower it so the bolt goes through the nylon spacer in the center hole of the top baseplate. Now thread the remaining 3/8" washer (H) and lock nut (I) onto the bolt's shaft. You might need to hold the bolt's head in place with another crescent wrench or pliers. Tighten the lock nut with the wrench just enough to allow a slight separation of the top and bottom baseplates when the mount is lifted. The purpose of the lock nut is merely to keep the two baseplates from coming apart when moving the telescope. Over-tightening the lock nut (I) will make the mount difficult to rotate in the azimuthal (horizontal) direction.

8. The rubber bumper (L) provides a convenient "stop" for the telescope's altitude motion; it prevents the telescope mirror cell from being knocked against the hard surface of the base's front brace. At the bottom of the interior surface of the front brace, you will notice a small index mark engraved. Remove the backing from the rubber bumper and position the bumper over the index mark, as shown in Figure 3. Press firmly so the adhesive holds the bumper securely in place.

Installing the Eyepiece Rack



Figure 3. Position the rubber bumper "stop" over the index mark on the inside surface of the front brace.

The aluminum eyepiece rack holds three 1.25" eyepieces in a convenient place on the base, within easy reach while you're observing. A 1.25" barlow can also be held in the rack. You can install the rack so that it can be removed, or you can



Figure 4. Using the two supplied screws, install the aluminum eyepiece rack in the predrilled holes about halfway down the left side panel of the base.

install it so it is permanently attached. About halfway down the left side panel of the base you will notice two predrilled starter holes, about 4" apart. Take the black wood screws that come packaged with the rack and thread them into the starter holes about three turns. Then you can "keyhole" the eyepiece rack onto the wood screws and continue tightening the screws. If you want to be able to remove the rack, do not tighten the screws too tightly. Be certain that the screws are loose enough that you can lift the rack and remove it from the screws through the larger part of the hole. If you want to have the rack permanently attached, attach the screws tightly. (Figure 4)



Figure 5. Set the optical tube on the "cradle" of the base so that the altitude side bearings on the tube rest on the white plastic "pads." Position the telescope as shown so that it won't fall down before the CorrecTension System is installed and engaged.

Placing the Optical Tube on the Dobsonian Base

Lift the optical tube and set the altitude bearings on either side of the tube in the "cradle" of the base. The tube will not yet be properly balanced, since the CorrecTension system has not been installed. Keep the tube positioned upright, as shown in Figure 5, for now.

Installing the CorrecTension (XT) Friction Optimization System

To install the CorrecTension assembly, follow these steps while referring to Figure 6:

1. Put one of the black nylon spacers on a black Phillips-head screw. The spacer should be oriented so the narrow end

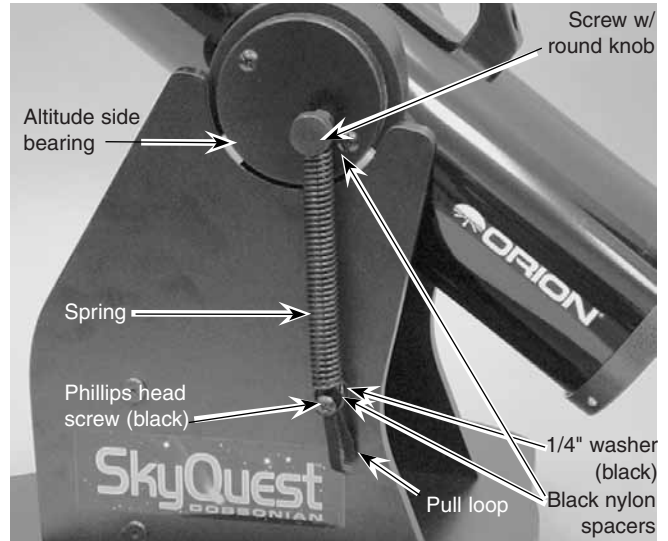

Figure 6. Close-up view of the CorrecTension System.

seats against the head of the screw. Slip one of the black 1/4" washers over the end of the screw. Now, thread the screw into the hole in the base side panel just below the cradle. The screw will thread into the preinstalled insert in the hole. Use a Phillips screwdriver to tighten the bolt. Repeat this procedure on the opposite side panel.

2. Next, insert one of the screws with round plastic knob attached through the end ring of one of the springs. Slip a black nylon spacer onto the screw. Orient the spacer so the narrow end is closest to the knob. Thread the entire assembly into the hole with the brass insert in the telescope's altitude side bearing until tight. The end ring of the spring should seat onto the narrow end of the spacer. Repeat this procedure for the other altitude side bearing.
3. Attach a pull loop to the free end of each spring. Slide the loop through the opening in the ring on the end of the spring.
4. Now, pull each spring down using the pull loop, and position the spring's end ring over the head of the black Phillips screw (installed in step 1) and onto the narrow part of the nylon spacer, as shown in Figure 7. You needn't attach both springs simultaneously; one at a time is fine.

The CorrecTension system is now installed and engaged. If you wish to remove the telescope tube from the base, you will first need to disconnect the springs from the "posts" on the Dobsonian base. Remember to position the tube upright before doing this, or the tube will fall over. The springs will remain captive on the altitude side bearings, so they will not get lost.

Installing the Finder Scope

The SkyQuest XT4.5 comes with a high quality, 6x26 correct-image achromatic finder scope. (Figure 8a) The "6" means it magnifies 6 times, the "26" means it has a 26mm effective diameter lens, and the correct-image means the image in the finder scope will appear right side up, just like the view through your naked eye.



Figure 7: (a) To attach the spring to the base, grip the pull loop with your index finger and pull down on the spring. (b) While pulling down, slip the end ring of the spring over the screw head and onto the narrow part of the nylon spacer, then release the pull loop.

To place the finder scope in the finder scope bracket, first unthread the two black nylon screws until the screw ends are flush with the inside diameter of the bracket. Place the O-ring that comes on the base of the bracket over the body of the finder scope until it seats into the groove on the middle of the finder scope. Slide the eyepiece end (narrow end) of the finder scope into the end of the bracket's cylinder that does not have the alignment screws while pulling the chrome, spring-loaded tensioner on the bracket with your fingers (see Figure 8b). Push the finder scope through the bracket until the O-ring seats just inside the front opening of the bracket's cylinder. Now, release the tensioner and tighten the two black nylon screws a couple of turns each to secure the finder scope in place. The tips of the tensioner and nylon screws should seat into the wide groove on the rear of the finder scope's body.

Slide the base of the finder scope bracket into the dovetail holder on the top of the focuser. Lock the bracket into position by tightening the knurled thumbscrew on the dovetail holder.

Inserting an Eyepiece

The final step in the assembly process is to insert an eyepiece into the telescope's focuser. Take the cover cap off the end of the focuser drawtube. Loosen the thumbscrews on the focuser drawtube and insert one of the eyepieces. Secure it in place by re-tightening the thumbscrews.

The assembly of your SkyQuest Dobsonian is now complete. It should appear as shown in Figure 1. The dust cap on the front of the telescope tube should always remain in place when the telescope is not in use. It is also a good idea to store eyepieces in an eyepiece case and to replace the cover caps on the focuser drawtube and on both ends of the finder scope when the telescope is idle.



Figure 8a: The 6x26 correct-image finder scope and bracket.



Figure 8b: Inserting the finder scope into the finder scope bracket

3. Using Your Telescope

It is best to get a feel for the basic functions of the SkyQuest XT4.5 during the day, before observing astronomical objects at night. This way you will not have to fumble around trying to orient yourself in the dark! Find a spot outdoors where you

have plenty of room to move around the telescope, and where you have a clear view of some object or vista that is at least 1/4-mile away. It is not critical that the base be exactly level, but it should be placed on somewhat flat ground or pavement to ensure smooth movement of the telescope.

Keep in mind that the SkyQuest XT4.5 was designed specifically for visual observation of astronomical objects in the night sky. Like all Dobsonians, it is not well-suited for daytime, terrestrial usage. This is due to the inverted images the Newtonian reflector optics provide and the low eyepiece height when pointed near the horizon. We recommend getting started during the day with the telescope, but remember that this is not the intended use. If you find that you want to do more daytime viewing of landscapes and vistas, you may want to consider purchasing a spotting scope.

Remember, never point the telescope at or near the Sun without using a proper solar filter over the front aperture!



Figure 9: (a) Many people find the SkyQuest XT4.5 convenient to use while sitting. (b) You can use the telescope while standing by placing it on a sturdy table. (c) If the table is too tall, try something a bit shorter, like a milk crate.

Sit Down or Stand Up?

One of the great assets of the SkyQuest XT4.5 is its extremely portable size. Due to its overall short height, most adults will find that observing while sitting on a chair or stool is most comfortable. If wanting to stand, a sturdy table of appropriate height will provide an adequate platform on which to place the telescope. Other platforms, such as a milk crate, can also be employed in order to achieve a range of eyepiece heights. (Figure 9)

Younger children will find that the telescope is a perfect height for them to use while standing; this is one of the reasons that it is ideal for budding young astronomers.

Altitude and Azimuth

The Dobsonian base of the SkyQuest XT4.5 permits motion of the telescope along two axes: altitude (up/down) and azimuth (left/right) (see Figure 10). This is very convenient, since up/down and left/right are the most “natural” ways that people aim. As a result, pointing the telescope is exceptionally easy.

Simply take hold of the telescope (Figure 11) and move it left or right so the base rotates about its central azimuth bolt, and move it up or down so the altitude side bearings rotate in the base’s cradle. Both motions can be made simultaneously and in a continuous manner for easy aiming. Move the telescope



Figure 10. The SkyQuest has two axes of motion: altitude (up/down) and azimuth (left/right).

gently - let it glide. In this way you can point the telescope to any position in the night sky, from horizon to horizon.

One of the unique features of the SkyQuest XT is the Navigation Knob located underneath the telescope tube near the open end. This knob makes for easy, smooth movement of the telescope. You can use it to move the telescope in both the azimuth and altitude directions.

You may find it convenient to hold your other hand near the rear of the telescope tube to steady it while moving and aiming the telescope.

Focusing the Telescope



Figure 11: Try grasping the telescope as shown for easiest pointing. The left hand uses the Navigation Knob as a “handle”, while the right hand is on the rear of the tube.

Insert the low-power 25mm eyepiece into the focuser and secure with the thumbscrew. Move the telescope so the front (open) end is pointing in the general direction of an object at least 1/4-mile away. Now, with your fingers, slowly rotate one of the focuser knobs until the object comes into sharp focus. Go a little bit beyond sharp focus until the image just starts to

blur again, then reverse the rotation of the knob, just to make sure you've hit the exact focus point.

If you have trouble focusing, rotate the focuser knob so the drawtube is in as far as it will go. Now look through the eyepiece while slowly rotating the focuser knob in the opposite direction. You should soon see the point at which focus is reached.

Viewing with Eyeglasses

If you wear eyeglasses, you may be able to keep them on while you observe, if the eyepiece has enough "eye relief" to allow you to see the whole field of view. You can try this by looking through the eyepiece first with your glasses on and then with them off, and see if the glasses restrict the view to only a portion of the full field. If they do, you can easily observe with your glasses off by just refocusing the telescope the needed amount. If you suffer from severe astigmatism, however, you may find images noticeably sharper with your glasses on.

Aligning the Finder Scope

The finder scope must be aligned accurately with the telescope for proper use. To align it, first aim the main telescope in the general direction of an object at least 1/4-mile away — the top of a telephone pole, a chimney, etc. Position that object in the center of the telescope's eyepiece.

Now, look in the finder scope. Is the object visible? Ideally, it will be somewhere in the field of view. If it is not, some coarse adjustments of the two finder scope alignment thumbscrews will be needed to get the finder scope roughly parallel to the main tube. **Note: The image in the main telescope will appear upside-down (rotated 180°). This is normal for reflector telescopes (see Figure 12). Your finder scope is a correct image finder, so the images will be right-side up.**

With the image in the finder scope's field of view, you will now use the two alignment thumbscrews to center the object on the intersection of the crosshairs.



Figure 12. The view through a reflector telescope is upside down. This is true for the SkyQuest XT4.5. The view through the correct-image finder scope, however will be right-side up, oriented the same as seen with the naked eye.

By turning the alignment thumbscrews, you change the line of sight of the finder scope. Continue making adjustments to the alignment thumbscrews until the images in both the finder scope and the telescope's eyepiece are exactly centered.

Check the alignment by moving the telescope to another object and fixing the finder scope's crosshairs on the exact point you want to look at. Then look through the telescope's eyepiece to see if that point is centered in the field of view. If it is, the job is done. If not, make the necessary adjustments to the finder scope alignment thumbscrews until the two images match up.

The finder scope alignment needs to be checked before every observing session. This can easily be done at night, before viewing through the telescope. Choose any bright star or planet, center the object in the telescope eyepiece, and then adjust the finder scope alignment thumbscrews until the star or planet is also centered on the finder's crosshairs. The finder scope is an invaluable tool for locating objects in the night sky; its usage for this purpose will be discussed later, in detail.

Focusing the Finder Scope

If, when looking through the finder scope, the images appear somewhat out of focus, you will need to refocus the finder scope for your eyes. Loosen the lock ring located behind the objective lens cell on the body of the finder scope (see Figure 8a). Back the lock ring off by a few turns, for now. Refocus the finder scope on a distant object by threading the objective lens cell in or out on the finder scope body. Precise focusing will be achieved by focusing the finder scope on a bright star. Once the image appears sharp, retighten the lock ring behind the objective lens cell. The finder scope's focus should not need to be adjusted again.

Aiming/Pointing the Telescope

Now that the finder scope is aligned, the telescope can be quickly and accurately pointed at anything you wish to observe. The finder scope has a much wider field of view than the telescope's eyepiece, and therefore it is much easier to first center an object in the finder scope. Then, if the finder scope is accurately aligned, the object will also be centered in the telescope's field of view.

Start by once again moving the telescope until it is pointed in the general direction of the object you want to see. Some observers find it convenient to sight along the tube to do this. Now, look in the finder scope. If your general aim is accurate, the object should appear somewhere in the finder scope. Make small adjustments to the telescope's position until the object is centered on the finder's crosshairs. Now, look in the telescope's eyepiece and enjoy the view!

Magnification

Now that the object you want to view is well centered in the 25mm eyepiece, you may want to increase the magnification to get a closer view. Loosen the thumbscrew on the focuser drawtube and remove the eyepiece. Insert the 10mm eyepiece in the focuser then tighten the thumbscrew. If you were careful not to bump the telescope, the object should still be

centered within the field of view. Notice that the object being viewed is now larger, but somewhat dimmer.

The SkyQuest XT4.5 is designed to accept any eyepiece with a barrel diameter of 1.25". Magnification, or power, is determined by the focal length of the telescope and the focal length of the eyepiece. Therefore, by using eyepieces of different focal lengths, the magnification can be varied.

Magnification is calculated as follows:

$$\text{Magnification} = \frac{\text{Telescope Focal Length (mm)}}{\text{Eyepiece Focal Length (mm)}}$$

The SkyQuest XT4.5 Dobsonian has a focal length of 910mm. So, the magnification with the supplied 25mm eyepiece is $910\text{mm} \div 25\text{mm} = 36\text{x}$. The magnification provided by the 10mm eyepiece is $910\text{mm} \div 10\text{mm} = 91\text{x}$.

The maximum attainable magnification for a telescope is directly related to how much light its optics can collect. A telescope with more light collecting area, or aperture, can yield higher magnifications than a smaller aperture telescope. The maximum practical magnification for any telescope, regardless of optical design, is about 50x per inch of aperture. This translates to about 225x for the SkyQuest XT4.5.

Maximum magnifications are achieved only under the most ideal viewing conditions at the best observing sites. Most of the time, magnifications are limited to 200x or less, regardless of aperture. This is because the Earth's atmosphere distorts light as it passes through. On nights of good "seeing", the atmosphere will be still and will yield the least amount of distortion. On nights of poor seeing, the atmosphere will be turbulent, which means different densities of air are rapidly mixing. This causes significant distortion of the incoming light, which prevents sharp views at high magnifications.

Keep in mind that as magnification is increased, the brightness of the object being viewed will decrease; this is an inherent principle of the physics of optics and cannot be avoided. If magnification is doubled, an image appears four times dimmer. If magnification is tripled, image brightness is reduced by a factor of nine!

Carrying the Telescope

Moving the SkyQuest XT4.5 is exceptionally easy to do. Because the springs of the CorrecTension system hold the optical tube captive on the base, the entire telescope can be carried as one unit. Simply grab the entire unit by the handle on the tube (see Figure 13), and away you go!

DO NOT TRY TO CARRY THE TELESCOPE BY THE NAVIGATION KNOB. ONLY USE THE CARRYING HANDLE!

Make sure that the thumbscrews that secure the eyepiece in the focuser are tightened, or it may fall out during transport. Better yet, remove the eyepiece from the focuser and store it in an appropriate eyepiece/accessory case.

If you wish to carry the optical tube and base separately, simply disengage the CorrecTension springs by unhooking them from the posts on the base, using the pull loops. Make sure



Figure 13: Transporting the SkyQuest XT4.5 is exceptionally easy. Just grab the handle and go!

the tube is positioned upright before doing this. The springs remain captive on the telescope side bearings. Now the base and tube are disengaged and can be transported separately.

When putting the SkyQuest into a vehicle, common sense prevails. It is especially important that the optical tube does not knock around; this can cause the optics to become misaligned, and could dent the tube. We recommend transporting the telescope in a carry case for proper protection.

4. Observing Tips

For many users, the SkyQuest XT4.5 telescope will be a major leap into the world of amateur astronomy. This section is intended to get you ready for your first voyage through the night sky.

Site Selection

Pick a location away from streetlights and bright yard lighting. Avoid viewing over rooftops and chimneys, as they often have warm air currents rising from them, which distort the image seen in the eyepiece. Similarly, you should not observe through an open window from indoors. Better yet, choose a site out-of-town, away from any "light pollution". You'll be stunned at how many more stars you'll see! Most importantly, make sure that any chosen site has a clear view of a large portion of the sky.

Cooling the Telescope

All optical instruments need time to reach "thermal equilibrium" to achieve maximum stability of the lenses and mirrors, which is essential for peak performance. When moved from a warm indoor location outside to cooler air (or vice-versa), a telescope needs time to cool (or warm) to the outdoor temperature. The bigger the instrument and the larger the temperature change, the more time will be needed.

Allow at least 30 minutes for your SkyQuest XT4.5 to equilibrate. If the scope experiences more than a 40° temperature change, allow an hour or more. In the winter, storing the telescope outdoors in a shed or garage greatly reduces the amount of time needed for the optics to stabilize. It also is a good idea to keep the scope covered until the Sun sets so the tube does not heat greatly above the temperature of the outside air.

Seeing and Transparency

Atmospheric conditions play a huge part in quality of viewing. In conditions of good “seeing”, star twinkling is minimal and objects appear steady in the eyepiece. Seeing is best overhead, worst at the horizon. Also, seeing generally gets better after midnight, when much of the heat absorbed by the Earth during the day has radiated off into space. Typically, seeing conditions will be better at sites that have an altitude over about 3000 feet. Altitude helps because it decreases the amount of distortion-causing atmosphere you are looking through.

A good way to judge if the seeing is good or not is to look at bright stars about 40° above the horizon. If the stars appear to “twinkle”, the atmosphere is significantly distorting the incoming light, and views at high magnifications will not appear sharp. If the stars appear steady and do not twinkle, seeing conditions are probably good and higher magnifications will be possible. Also, seeing conditions are typically poor during the day. This is because the heat from the Sun warms the air and causes turbulence.

Good “transparency” is especially important for observing faint objects. It simply means the air is free of moisture, smoke, and dust which tend to scatter light, reducing an object's brightness. One good way to tell if conditions are good is by how many stars you can see with your naked eye. If you cannot see stars of magnitude 3.5 or dimmer then conditions are poor. Magnitude is a measure of a star's brightness. The brighter a star is, the lower its magnitude will be. A good star to remember for this is Megrez (mag. 3.4), which is the star in the ‘Big Dipper’ connecting the handle to the ‘dipper’. If you cannot see Megrez, then you have fog, haze,

clouds, smog, or other conditions that are hindering your viewing. (See Figure 14)

Let Your Eyes Dark-Adapt

Do not expect to go from a lighted house into the darkness of the outdoors at night and immediately see faint nebulas, galaxies, and star clusters — or even very many stars, for that matter. Your eyes take about 30 minutes to reach perhaps 80% of their full dark-adapted sensitivity. Many observers notice improvements after several hours of total darkness. As your eyes become dark-adapted, more stars will glimmer into view and you will be able to see fainter details in objects you view in your telescope. So give yourself at least a little while to get used to the dark before you begin observing.

To see what you are doing in the darkness, use a red light flashlight rather than a white light. Red light does not spoil your eyes’ dark adaptation like white light does. A flashlight with a red LED light is ideal, or you can cover the front of a regular flashlight with red cellophane or paper. Beware, too, that nearby porch and streetlights and automobile headlights will spoil your night vision.

5 Astronomy Basics

Tracking Celestial Objects

The Earth is constantly rotating about its polar axis, completing one full rotation every 24 hours; this is what defines a “day”. We do not feel the Earth rotating, but we can tell that it is at night by seeing the apparent movement of stars from east to west. This movement translates into a rate of approximately .25° per minute, or 15 arc-seconds per second. (There are 60 arc-minutes in 1°, and 60 arc-seconds in one arc-minute.) This is called the sidereal rate.

When you observe any astronomical object, you are watching a moving target. This means the telescope's position must be continuously updated over time to keep an object in the field of view. This is easy to do with the SkyQuest XT4.5 because of its smooth motions on both axes. As the object moves off toward the edge of the field of view, you just lightly nudge the telescope to bring it back to the center.

You will notice that it is more difficult to “track” objects when the telescope tube is aimed nearly straight up. This is inherent to the basic design of the Dobsonian, and stems from the fact that there is very little mechanical leverage to move in azimuth when the tube is in a near vertical position. To gain more leverage, try grasping the tube close to the altitude side bearings with both hands.

Remember that objects appear to move across the field of view faster at higher magnifications. This is because the field of view becomes narrower.

Eyepiece Selection

By using eyepieces of varying focal lengths, it is possible to attain many magnifications with the SkyQuest XT4.5. The telescope comes with two high-quality Sirius Plössl eyepieces: a 25mm, which gives a magnification of 36x, and a 10mm,

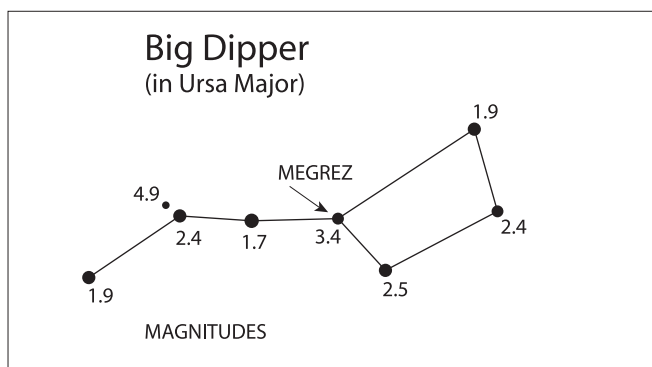

Figure 14. Megrez connects the Big Dipper's handle to its “pan”. It is a good guide to how conditions are. If you can not see Megrez (a 3.4 mag star) then conditions are poor.

which gives a magnification of 91x. Other eyepieces can be used to achieve higher or lower powers. It is quite common for an observer to own five or more eyepieces to access a wide range of magnifications. This allows the observer to choose the best eyepiece to use depending on the object being viewed. At least to begin with, the two supplied eyepieces will suffice nicely.

Whatever you choose to view, always start by inserting your lowest-power (longest focal length) eyepiece to locate and center the object. Low magnification yields a wide field of view, which shows a larger area of sky in the eyepiece. This makes acquiring and centering an object much easier. If you try to find and center objects with high power (narrow field of view), it's like trying to find a needle in a haystack!

Once you've centered the object in the eyepiece, you can switch to higher magnification (shorter focal length eyepiece), if you wish. This is especially recommended for small and bright objects, like planets and double stars. The Moon also takes higher magnifications well.

Deep-sky objects, however, typically look better at medium or low magnifications. This is because many of them are quite faint, yet have some extent (apparent width). Deep-sky objects will often disappear at higher magnifications, since greater magnification inherently yields dimmer images. This is not the case for all deep-sky objects, however. Many galaxies are quite small, yet are somewhat bright, so higher power may show more detail.

The best rule of thumb with eyepiece selection is to start with a low power, wide field, and then work your way up in magnification. If the object looks better, try an even higher magnification. If the object looks worse, then back off the magnification a little by using a lower-power eyepiece.

Now that you are all set up and ready to go, one critical decision must be made: what to look at?

What to Expect

So what will you see with your telescope? You should be able to see bands on Jupiter, the rings of Saturn, craters on the moon, the waxing and waning of Venus, and possibly hundreds of deep sky objects. Do not expect to see any color as you do in NASA photos, since those are taken with long-exposure cameras and have 'false color' added. Our eyes are not sensitive enough to see color in deep-sky objects except in a few of the brightest ones.

Remember that you are seeing these objects using your own telescope with your own eyes! The object you see in your eyepiece is in real-time, and not some conveniently provided image from an expensive space probe. Each session with your telescope will be a learning experience. Each time you work with your telescope it will get easier to use, and stellar objects will become easier to find. Take it from us, there is big difference between looking at a well-made full-color NASA image of a deep-sky object in a lit room during the daytime, and seeing that same object in your telescope at night. One can merely be a pretty image someone gave to you. The other is an experience you will never forget!

A. The Moon

With its rocky surface, the Moon is one of the easiest and most interesting targets to view with your telescope. Lunar craters, marias, and even mountain ranges can all be clearly seen from a distance of 238,000 miles away! With its ever-changing phases, you'll get a new view of the Moon every night. The best time to observe our one and only natural satellite is during a partial phase, that is, when the Moon is NOT full. During partial phases, shadows are cast on the surface, which reveal more detail, especially right along the border between the dark and light portions of the disk (called the "terminator"). A full Moon is too bright and devoid of surface shadows to yield a pleasing view.

Use an optional Moon filter to dim the Moon when it is very bright. It simply threads onto the bottom of the eyepieces (you must first remove the eyepiece from the focuser to attach a filter). You'll find that a Moon filter improves viewing comfort, and also helps to bring out subtle features on the lunar surface.

B. The Sun

You can change your nighttime telescope into a daytime Sun viewer by installing an optional full-aperture solar filter over the front opening of a SkyQuest XT4.5. The primary attraction is sunspots, which change shape, appearance, and location daily. Sunspots are directly related to magnetic activity in the Sun. Many observers like to make drawings of sunspots to monitor how the Sun is changing from day to day.

Important Note: Do not look at the Sun with any optical instrument without a professionally made solar filter, or permanent eye damage could result.

C. The Bright Planets

The planets don't stay put like the stars, so to find them you should refer to Sky Calendar at our website (www.telescope.com), or to charts published monthly in Astronomy, Sky & Telescope, or other astronomy magazines. Venus, Mars, Jupiter, and Saturn are the brightest objects in the sky after the Sun and the Moon. Your SkyQuest XT is capable of showing you these planets in some detail. Other planets may be visible but will likely appear starlike. Because planets are quite small in apparent size, optional higher-power eyepieces are recommended and often needed for detailed observations. Not all the planets are usually visible at any one time.

JUPITER The largest planet, Jupiter, is a great subject for observation. You can see the disk of the giant planet and watch the ever-changing positions of its four largest moons—Io, Callisto, Europa, and Ganymede. Higher power eyepieces should bring out the cloud bands on the planet's disk.

SATURN The ringed planet is a breathtaking sight when it is well positioned. The tilt angle of the rings varies over a period of many years; sometimes they are seen edge-on, while at other times they are broadside and look like giant "ears" on each side of Saturn's disk. A steady atmosphere (good seeing) is necessary for a good view. You will probably see a bright "star" close by, which is Saturn's brightest moon, Titan.

VENUS At its brightest, Venus is the most luminous object in the sky, excluding the Sun and the Moon. It is so bright that sometimes it is visible to the naked eye during full daylight! Ironically, Venus appears as a thin crescent, not a full disk, when at its peak brightness. Because it is so close to the Sun, it never wanders too far from the morning or evening horizon. No surface markings can be seen on Venus, which is always shrouded in dense clouds.

MARS The Red Planet makes its closest approach to Earth every two years. During close approaches you'll see a red disk, and may be able to see the polar ice cap. To see surface detail on Mars, you will need a high power eyepiece and very steady air!

D. The Stars

Stars will appear like twinkling points of light. Even powerful telescopes cannot magnify stars to appear as more than a point of light! You can, however, enjoy the different colors of the stars and locate many pretty double and multiple stars. The famous "Double-Double" in the constellation Lyra and the gorgeous two-color double star Albireo in Cygnus are favorites. Defocusing a star slightly can help bring out its color.

E. Deep-Sky Objects

Under dark skies, you can observe a wealth of fascinating deep-sky objects, including gaseous nebulas, open and globular star clusters, and a variety of different types of galaxies. Most deep-sky objects are very faint, so it is important that you find an observing site well away from light pollution. Take plenty of time to let your eyes adjust to the darkness. Do not expect these subjects to appear like the photographs you see in books and magazines; most will look like dim gray smudges. (Our eyes are not sensitive enough to see color in deep-sky objects except in a few of the brightest ones.) But as you become more experienced and your observing skills get sharper, you will be able to ferret out more and more subtle details and structure.

How to Find Deep-sky Objects: Starhopping

Starhopping, as it is called by astronomers, is perhaps the simplest way to hunt down objects to view in the night sky. It entails first pointing the telescope at a star close to the object you wish to observe, and then progressing to other stars closer and closer to the object until it is in the field of view of the eyepiece. It is a very intuitive technique that has been employed for hundreds of years by professional and amateur astronomers alike. Keep in mind, as with any new task, that starhopping may seem challenging at first, but will become easier over time and with practice.

To starhop, only a minimal amount of additional equipment is necessary. A star chart or atlas that shows stars to at least magnitude 5 is required. Select one that shows the positions of many deep-sky objects, so you will have a lot of options to choose from. If you do not know the positions of the constellations in the night sky, you will need to get a planisphere to identify them.

Start by choosing bright objects to view. The brightness of an object is measured by its visual magnitude; the brighter

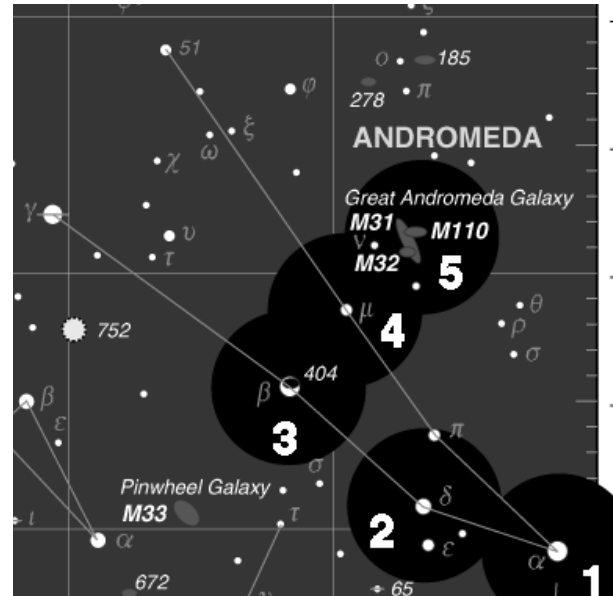

Figure 15. Starhopping is a good way to locate hard-to-find objects. Refer to a star chart to map a route to the object that uses bright stars as guideposts. Center the first star you've chosen in the finder scope and telescope eyepiece (1). Now move the scope carefully in the direction of the next bright star (2), until it is centered. Repeat (3 and 4). The last hop (5) should place the desired object in the eyepiece.

an object, the lower its magnitude. Choose an object with a visual magnitude of 9 or lower. Many beginners start with the Messier objects, which represent some of the best and brightest deep-sky objects, first catalogued about 200 years ago by the French astronomer Charles Messier.

Determine in which constellation the object lies. Now, find the constellation in the sky. If you do not recognize the constellation on sight, consult a planisphere. The planisphere gives an all-sky view and shows which constellations are visible on a given night at a given time.

Now look at your star chart and find the brightest star in the constellation that is near the object that you are trying to find. Using the finder scope, point the telescope at this star and center it on the crosshairs. Next, look again at the star chart and find another suitably bright star near the bright star currently centered in the finder. Keep in mind that the field of view of the finder scope is 6° , so you should choose a star that is no more than 6° from the first star, if possible. Move the telescope slightly, until the telescope is centered on the new star.

Continue using stars as guideposts in this way until you are the approximate position of the object you are trying to find (Figure 15). Look in the telescope's eyepiece, and the object should be somewhere within the field of view. If it's not, sweep the telescope carefully around the immediate vicinity until the object is found.

If you have trouble finding the object, start the starhop again from the brightest star near the object you wish to view. This time, be sure the stars indicated on the star chart are in fact the stars you are centering in the finder scope and telescope

eyepiece. Remember the telescope gives you inverted images, but the finder scope does not.

6 Care and Maintenance

If you give your telescope reasonable care, it will last a lifetime. Store it in a clean, dry, dust free place, safe from rapid changes in temperature and humidity. Do not store the telescope outdoors, although storage in a garage or shed is OK. Small components like eyepieces and other accessories should be kept in a protective box or storage case. Keep the caps on the front of the scope and on the focuser when it is not in use. For maximum protection during storage, we recommend placing the telescope in a case to prevent any dust and moisture from accumulating on exposed surfaces.

The telescope requires very little mechanical maintenance. The optical tube is made of steel and has a smooth painted finish that is fairly scratch-resistant. If a scratch does appear on the tube, it will not harm the telescope. If you wish, you may apply some auto touch-up paint to the scratch. Smudges on the tube can be wiped off with a soft cloth and a household cleaner such as Windex or Formula 409.

Refer to Appendix B for detailed instructions on how to clean the optics of the SkyQuest XT4.5.

7. Specifications

Focal Length: 900mm

Aperture: 114mm (4.5")

Focal Ratio: f/7.9

Mirror Coatings: aluminum with SiO₂ overcoat, 89% reflective

Minor Axis of secondary mirror: 28mm

Weight: 17.6 lbs. (tube and base)

Tube Length: 35"

Tube Outer Diameter: 5.5"

Appendix A: Collimation (Aligning the Mirrors)

Collimation is the process of adjusting the mirrors so they are perfectly aligned with one another. Your telescope's optics were aligned at the factory, and should not need much adjustment unless the telescope is handled roughly. Accurate mirror alignment is important to ensure the peak performance of your telescope, so it should be checked regularly. Collimation is relatively easy to do and can be done in daylight.

To check collimation, remove the eyepiece and look down the focuser drawtube. You should see the secondary mirror centered in the drawtube, as well as the reflection of the primary mirror centered in the secondary mirror, and the reflection of the secondary mirror (and your eye) centered in the reflection of the primary mirror, as in Figure 16a. If anything is off-center, as in Figure 16b, proceed with the following collimation procedure.

The Collimation Cap and Mirror Center Mark

Your SkyQuest XT4.5 comes with a collimation cap. This is a simple cap that fits on the focuser drawtube like a dust cap, but has a hole in the center and a silver bottom. This helps center your eye so that collimation is easy to perform. Figures 16b-e assume you have the collimation cap in place.

In addition to providing the collimation cap, you'll notice a tiny ring (sticker) in the exact center of the primary mirror. This "center mark" allows you to achieve a very precise collimation of the primary mirror; you don't have to guess where the center of the mirror is. You simply adjust the mirror position (described below) until the reflection of the hole in the collimation cap is centered inside the ring. This center mark is also required for best results with other collimating devices, such as Orion's LaserMate Laser Collimator, obviating the need to remove the primary mirror and mark it yourself.

NOTE: The center ring sticker need not ever be removed from the primary mirror. Because it lies directly in the shadow of the secondary mirror, its presence in no way adversely affects the

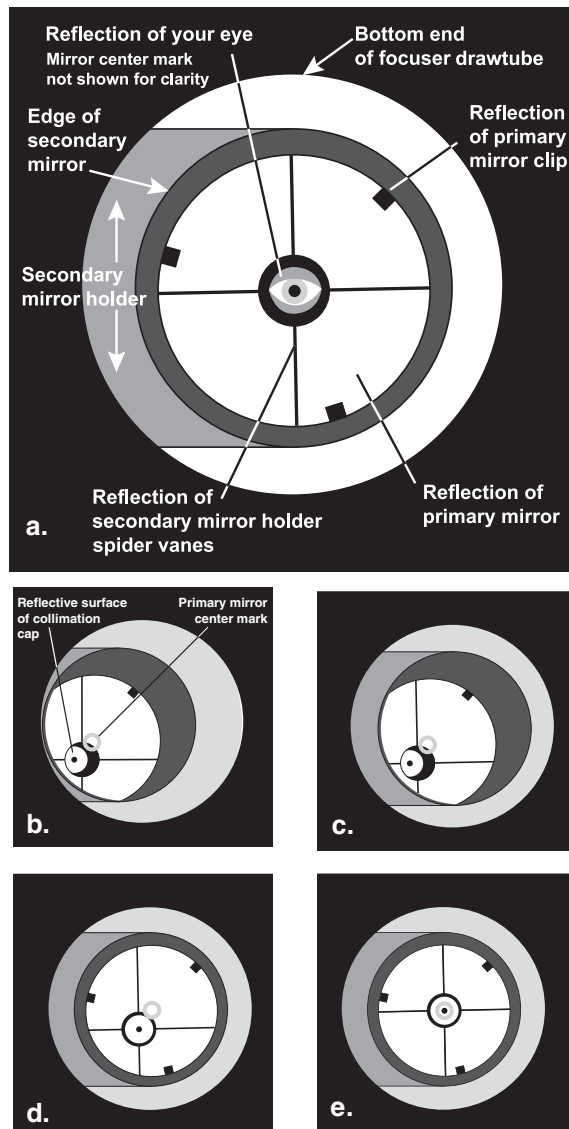

Figure 16. Collimating the optics. (a) When the mirrors are properly aligned, the view down the focuser drawtube should look like this. (b) With the collimation cap in place, if the optics are out of alignment, the view might look something like this. (c) Here, the secondary mirror is centered under the focuser, but it needs to be adjusted (tilted) so that the entire primary mirror is visible. (d) The secondary mirror is correctly aligned, but the primary mirror still needs adjustment. When the primary mirror is correctly aligned, the "dot" will be centered, as in (e).

optical performance of the telescope or the image quality. That might seem counterintuitive, but it's true!

Aligning the Secondary Mirror

With the collimation cap in place, look through the hole in the cap at the secondary (diagonal) mirror. Ignore the reflections for the time being. The secondary mirror itself should be centered in the focuser drawtube, in the direction parallel to the length of the telescope. If it isn't, as in Figure 16b, it must be adjusted. It helps to adjust the secondary mirror in a brightly lit room with the telescope pointed towards a bright surface, such as white paper or wall. Placing a piece of white paper in the telescope tube opposite the focuser (in other words, on the other side of the secondary mirror) will also be helpful in collimating the secondary mirror. Using a 2mm Allen wrench, loosen the three small alignment set screws in the center hub of the 4-vaned spider several turns. Now hold the secondary mirror holder stationary (be careful not to touch the mirror's surface), while turning the center screw with a Phillips head screwdriver (See Figure 17). Turning the screw clockwise will move the secondary mirror toward the front opening of the optical tube, while turning the screw counter-clockwise will move the secondary mirror toward the primary mirror. When making these adjustments, be careful not to stress the spider vanes or they may bend.

When the secondary mirror is centered in the focuser drawtube, rotate the secondary mirror holder until the reflection of the primary mirror is as centered in the secondary mirror as possible. It may not be perfectly centered, but that is OK. Now tighten the three small alignment screws equally

to secure the secondary mirror in that position. This adjustment will rarely, if ever need to be done.

If the entire primary mirror reflection is not visible in the secondary mirror, as in Figure 16c, you will need to adjust the tilt of the secondary mirror. This is done by alternately loosening one of the three alignment set screws while tightening the other two, as depicted in Figure 18. The goal is to center the primary mirror reflection in the secondary mirror, as in Figure 16d. Don't worry that the reflection



Figure 17. To center the secondary mirror under the focuser, hold the secondary mirror holder in place with your fingers while adjusting the center screw with the Phillips head screwdriver. Do not touch the mirror's surface.

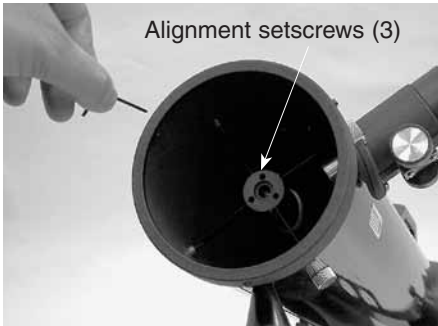

Figure 18. Adjust the tilt of the secondary mirror by loosening or tightening the three alignment set screws with a 2mm Allen wrench.

of the secondary mirror (the smallest circle, with the collimation cap "dot" in the center) is off-center. You will fix that in the next step.

Adjusting the Primary Mirror

The final adjustment is made to the primary mirror. It will need adjustment if, as in Figure 16d, the secondary mirror is centered under the focuser and the reflection of the primary mirror is centered in the secondary mirror, but the small reflection of the secondary mirror (with the "dot" of the collimation cap) is off-center.

The tilt of the primary mirror is adjusted with three spring-loaded collimation thumbscrews on the back end of the optical tube (bottom of the primary mirror cell); these are the wide thumbscrews. The other three thin thumbscrews lock the mirror's position in place; these thin thumbscrews must be loosened before any collimation adjustments can be made to the primary mirror.

To start, turn the thin thumbscrews that lock the primary mirror in place a few turns each (Figure 19).



Figure 19. The three thin thumbscrews that lock the primary mirror in place must first be loosened before any adjustments can be made.

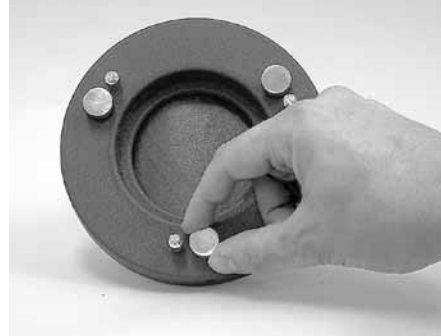

Figure 20. The tilt of the primary mirror is adjusted by turning one or more of the three wide collimation thumbscrews.

Now, try tightening or loosening one of the wide collimation thumbscrews with your fingers (Figure 20). Look into the focuser and see if the secondary mirror reflection has moved closer to the center of the primary. You can tell this easily with the collimation cap and mirror center mark by simply watching to see if the "dot" of the collimation cap is moving closer or further away from being centered in the "ring" of the primary mirror mark. When you have that dot centered as much as is possible in the ring, your primary mirror is collimated. The view through the collimation cap should resemble Figure 16e. Re-tighten the locking thumbscrews.

A simple star test will tell you whether the optics are accurately collimated.

Star-Testing

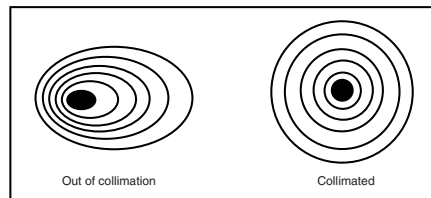

Figure 21. A star test will determine if the telescope's optics are properly collimated. An unfocused view of a bright star through the eyepiece should appear as

illustrated on the right if optics are perfectly collimated. If the circle is unsymmetrical, as illustrated on the left, the scope needs collimation.

the Telescope

When it is dark, point the telescope at a bright star and accurately center it in the eyepiece's field of view. Slowly de-focus the image with the focusing knob. If the telescope is correctly collimated, the expanding disk should be a perfect circle (Figure 21). If the image is unsymmetrical, the scope is out of collimation. The dark shadow cast by the secondary mirror should appear in the very center of the out-of-focus circle, like the hole in a donut. If the "hole" appears off-center, the telescope is out of collimation.

If you try the star test and the bright star you have selected is not accurately centered in the eyepiece, the optics will always appear out of collimation, even though they may be perfectly aligned. It is critical to keep the star centered, so over time you will need to make slight corrections to the telescope's position in order to account for the sky's apparent motion.

Appendix B: Cleaning the Optics

Cleaning Lenses

Any quality optical lens cleaning tissue and optical lens cleaning fluid specifically designed for multi-coated optics can be used to clean the exposed lenses of your eyepieces or finderscope. Never use regular glass cleaner or cleaning fluid designed for eyeglasses.

Before cleaning with fluid and tissue, blow any loose particles off the lens with a blower bulb or compressed air. Then apply some cleaning fluid to a tissue, never directly on the optics. Wipe the lens gently in a circular motion, then remove any excess fluid with a fresh lens tissue. Oily fingerprints and smudges may be removed using this method. Use caution—rubbing too hard may scratch the lens. On larger lenses, clean only a small area at a time, using a fresh lens tissue on each area. Never reuse tissues.

Cleaning Mirrors

You should not have to clean the telescope's mirror very often; normally once every year or so. Covering the telescope with the dust cap when it is not in use will help prevent dust from accumulating on the mirrors. Improper cleaning can scratch mirror coatings, so the fewer times you have to clean the mirrors, the better. Small specks of dust or flecks of paint have virtually no effect on the visual performance of the telescope.

The large primary mirror and the elliptical secondary mirror of your telescope are front-surface aluminized and overcoated with hard silicon dioxide, which prevents the aluminum from oxidizing. These coatings normally last through many years of use before requiring re-coating, which is easily done.

To clean the secondary mirror, it must be removed from the telescope. Do this by holding the secondary mirror holder stationary with your fingers (don't touch the mirror itself) while unthreading the Phillips head cap screw in the center hub

of the 4-vaned spider. Completely unthread the screw from the holder, and the holder will come loose in your fingers. Be careful not to lose the spring on the Phillips head cap screw.

Handle the mirror and its holder carefully. You do not need to remove the secondary mirror from its holder for cleaning. To clean the secondary mirror, follow the procedure described below for cleaning the primary mirror.

To clean the primary mirror, carefully remove the mirror cell from the telescope. To do this, you must remove the three screws that connect the entire mirror cell to the steel tube. These screws are located on the outer edge of the mirror cell casing.

Now, remove the mirror from the mirror cell by removing the three mirror clips that secure the mirror in its cell. Use a Phillips head screwdriver to unthread the mirror clip anchor screws. Next, hold the mirror by its edge, and remove it from the mirror cell. Be careful not to touch the aluminized surface of the mirror with your fingers. Set the mirror on a clean, soft towel. Fill a clean sink, free of abrasive cleanser, with room-temperature water, a few drops of liquid dishwashing detergent, and if possible, a cap-full of rubbing alcohol. Submerge the mirror (aluminized face up) in the water and let it soak for several minutes (or hours if it is a very dirty mirror). Wipe the mirror underwater with clean cotton balls, using extremely light pressure and stroking in straight lines across the surface. Use one ball for each wipe across the mirror. Then rinse the mirror under a stream of lukewarm water. Any particles on the surface can be swabbed gently with a series of clean cotton balls, each used just one time. Dry the mirror in a stream of air (a "blower bulb" works great), or remove any stray drops of water with the corner of a paper towel. Water will run off a clean surface. Dry the bottom and the edges (not the mirror surface!) with a towel. Cover the mirror surface with Kleenex, and leave the entire assembly in a warm area until it is completely dry before reassembling the telescope.

One-Year Limited Warranty

This Orion SkyQuest XT Dobsonian Reflecting Telescope is warranted against defects in materials or workmanship for a period of one year from the date of purchase. This warranty is for the benefit of the original retail purchaser only. During this warranty period Orion Telescopes & Binoculars will repair or replace, at Orion's option, any warranted instrument that proves to be defective, provided it is returned postage paid to: Orion Warranty Repair, 89 Hangar Way, Watsonville, CA 95076. If the product is not registered, proof of purchase (such as a copy of the original invoice) is required.

This warranty does not apply if, in Orion's judgment, the instrument has been abused, mishandled, or modified, nor does it apply to normal wear and tear. This warranty gives you specific legal rights, and you may also have other rights, which vary from state to state. For further warranty service information, contact: Customer Service Department, Orion Telescopes & Binoculars, 89 Hangar Way, Watsonville, CA 95076; (800) 676-1343.

Orion Telescopes & Binoculars

89 Hangar Way, Watsonville, CA 95076

Customer Support Help Line (800) 676-1343 • Day or Evening